

PREPRINT

© 2001 *Netherlands Journal of Zoology*

Courtship behaviour in lacertid lizards: phylogenetic interpretations of the *Lacerta kulzeri* complex (Reptilia: Lacertidae)

Running headline: Courtship analysis *Lacerta kulzeri* complex

H.A.J. IN DEN BOSCH¹ & M. ZANDEE²

(Leiden University, Institute of Evolutionary and Ecological Sciences, Sections Behavioural Biology¹ and Theoretical Biology & Phylogenetics², P.O. Box 9516, NL-2300 RA Leiden, The Netherlands)

Editorial correspondence:

H.A.J. in den Bosch

Fax: +31-71-527 4900

E-mail: indenbosch@rulsfb.LeidenUniv.nl

ABSTRACT

We investigate whether at a low taxonomic level an analysis of courtship provides useful phylogenetic information in lacertids. This leads to an understanding of the evolutionary development of courtship behaviour.

In a concise general description of lacertid courtship behaviour, four phases are distinguished: introduction, copulation, post-copulatory bite, and the period immediately after physical separation. The composing elements are described.

Observations on courtship displays of seven closely related putative species of lacertid lizards, *Lacerta cf. kulzeri*, are summarised in 38 behavioural traits, resulting in a data matrix analysed by PAUP. One most parsimonious cladogram (MPC) with 61 steps (corrected Consistency Index=.62) is found.

The study demonstrates that at a low taxonomic level (putative species) in lacertids, a behavioural analysis provides useful phylogenetic information, from which a reconstruction of the evolutionary development of courtship behaviour results.

In the *L. cf. kulzeri* complex, courtship seems to evolve towards a lengthening of the total duration. This trend is possibly correlated with an increased preference for a progressively more vegetated, horizontal microhabitat, after coming from a similar ancestral environment in lowland areas and going through an evolution in a more open, drier ecosystem of rocky outcrops at higher elevations. The character sets on the internal nodes of the cladogram do not seem to represent a coherent evolutionary pathway. These stages of evolutionary development appear to be interchangeable. Moreover, behavioural syndromes can hardly be recognised in the phylogenetic context.

Our cladogram is strictly based on apomorphic similarities, and all relationships among taxa depicted are based on recency of common ancestry. The only other diagram for this group available from the literature is based on overall morphological similarity. This dendrogram is considerably longer (69 steps) when the behavioural characters are mapped onto it. Parsimony mapping of behavioural characters on an as yet unpublished preliminary cladogram based on 12S rDNA data results in 65 steps. Consequently, we favour the behavioural cladogram.

Keywords: courtship behaviour, phylogeny, lacertid lizards, *Lacerta kulzeri* complex, *Lacerta laevis* complex, low taxonomic level.

INTRODUCTION

Despite work by early ethologists (HEINROTH, 1911; LORENZ, 1941; TINBERGEN, 1959), behavioural traits were traditionally rarely used to infer evolutionary relationships, and commonly judged inferior to other types of characters in systematics. It has even been claimed that behaviour has no value for reconstructing phylogenetic history (e.g. ATZ, 1970; ARONSON, 1981). Yet, more recently it has convincingly been argued that behavioural characters can and should be used as indicators of phylogeny (e.g. de QUEIROZ & WIMBERGER, 1993; RYAN, 1997).

Studies using behaviour to examine phylogenetic relationships concentrated on well-established and described taxa on the species level, while less attention has been given on whether a comparative behavioural analysis will help to clarify relationships within species complexes.

In this study, we will try to gain insight into the evolutionary relationships within a small group of presumably closely related Middle-Eastern lacertid lizards (with data

on seven forms). We employ quantitative phylogenetic methods to derive an hypothesis of evolutionary relationships (cladograms) using an analysis of courtship behaviour patterns. The resulting hypothesis will be compared with an independently derived cladogram obtained from non-behavioural data on the same group (pholidosis analyses: BISCHOFF & SCHMIDTLER, 1999; BISCHOFF & SCHMIDTLER, in prep.). Other, non-historical factors will be considered in connection with the results, to analyse possible correlations with habitat variables, and we will present an hypothesis concerning the evolution of the courtship patterns.

Fieldwork in the Middle East (*e.g.* IN DEN BOSCH, 1998) suggested that a number of populations originally ascribed to the common polymorphic wall lizard of the Middle East and Turkey, *Lacerta laevis* Gray, 1838, in fact are members of a distinct species complex. These forms seem to be confined to altitudes of more than 1300 m and in effect represent island populations. At the moment seven groups are distinguished (see table I), each confined to a mountain range. They have been provisionally referred (In den Bosch, 1998) to *Lacerta kulzeri* Müller & Wettstein, 1932, a lacertid originally described from the cedar wood at 1900 m near Bcharré, Makmel Mts., northern Lebanon.

The comparatively robust and ground dwelling *L. laevis* is distributed from sea level up to 1500 meters and can therefore be active for most of the year. The more slender and wary *Lacerta kulzeri* s.l. prefer rocky outcrops in comparatively dry zones with sparser vegetation, in altitudes ranging roughly from 1300-2000 m, and are thus active only during the warmer months (pers. obs.). In addition, in an ongoing karyological study, *L. laevis* and *L. cf. kulzeri* were of late found to be different (ODIERNA et al., 1998; IN DEN BOSCH et al., in prep.). Taxonomic work on the

Lacerta laevis-kulzeri complex is in progress (e.g. BISCHOFF & SCHMIDTLER, 1999; SCHMIDTLER & BISCHOFF, 1999).

In this paper, we use behavioural analysis on seven putative species of the *L. kulzeri* complex to examine their behavioural differences in courtship behaviour, and to assess their phylogenetic relationships.

MATERIALS AND METHODS

Courtship sessions (6-15, from at least two couples) of eight samples belonging to seven different *L. kulzeri* forms now recognised (BISCHOFF & SCHMIDTLER, 1999) and two *Lacerta laevis* forms (*L. l. laevis* and *L. l. troodica*) were videotaped and described (see table I for localities). All lizards were collected from the wild by In den Bosch (e.g. IN DEN BOSCH, 1999), except for the first sample of "Ma'alula" (BISCHOFF & SCHMIDTLER, 1994), the first batch of "Petra" (MÜLLER, 1995), and the "Dana" animals, belonging to the Petra form (collected by Modrý).

TABLE I: Localities of the *Lacerta kulzeri* complex (exact localities in BISCHOFF & SCHMIDTLER (1999, and in prep.) and IN DEN BOSCH (in ms)), and two *Lacerta laevis* subspecies.

| <i>Lacerta kulzeri</i> forms | Origin |
|------------------------------|------------------------------------|
| Barouk | Jabal Barouk: Lebanon |
| Druze | Jabal Druze: southern Syria |
| Hermon | Mt. Hermon: Lebanon, Syria, Israel |
| Ma'alula | Anti Lebanon Mts.: Lebanon, Syria |
| Northern Lebanon | Akkar region: Lebanon |
| Dana + Petra | Petra, Dana: Jordan |
| Sannin | Sannin and Makmel Mts.: Lebanon |
| <i>Lacerta laevis</i> forms | |
| <i>L. l. laevis</i> | Byblos: Lebanon |
| <i>L. l. troodica</i> | Kato Platres: Cyprus |

Details on maintenance of the lizards are as described in IN DEN BOSCH & BOUT (1998). A concise overview on the discovery of lizards referred to the *L. kulzeri* complex, was given by IN DEN BOSCH et al., 1998. The first of these forms was described recently (specimens from Dana and Petra: *Lacerta kulzeri petraea*) by BISCHOFF & MÜLLER (1999).

Courtship Behaviour

Four phases can be distinguished in lacertid courtship behaviour: introduction, copulation, post-copulatory bite, and the period immediately after physical separation. Each phase is characterised by a certain duration (appendix I; characters 1, 8, 28), except for the last phase, which has no clear-cut ending. The other characters are described below. Some of these traits occur in the same state among the members of the present group, but do vary in other lacertids that will be treated in later papers.

Introductory behaviour

In the threat display (2) the male raises his body off the ground, flattening it laterally, and distends the throat. A mating march (3) consists of the female pulling the male forwards and/or the male shoving the female forwards (3: 0=absent, 3: 1=indicated (either male or female shows elements of the mating march), 3: 2=present (both male and female shows elements of the mating march)).

Nodding frequency (4) and front-leg motions (5) are vertical movements of female appendages. The initial mating bite in the female by the male may be on the same side of her as later bites, or he may shift sides (6). Laterally undulating tail movements of the female in this phase can be noticed in some species (7).

Copulation

At the start of the copulation, the cloacae may be raised off the substrate (9). The male's front legs can be positioned somewhere on the female or on the substrate (10).

At the onset of copulation, tail lash(es) of the male (11) may be seen, somewhat irregular tail movements later on (13), and vertical front-leg motions of the female (12) can occur.

The bite grip position (14) is on the flank in the *kulzeri* group, but may vary in other lacertids. During copulation the male's head makes a certain angle in relation to the female's axis (15), and the male can make chewing movements (16), and/or jerk at the female with his jaws (18; not in the *kulzeri* group, but found in different patterns in other lacertids). Near the end he may or may not clearly open his jaws (17) to release the female. After a certain period tail-base motions of the male start which occur in a specific amplitude (19) and number (20), and may occur with a particular frequency change (21).

Near the end of the copulation a series of very rapid cloacal end thrusts by the male can occur (22), or a few solitary end thrusts take place (23), and male tail lash(es) (24) may be present or absent. Further, his tail relaxes (25) in a certain fashion near the end. Finally, the male pulls his cloaca away (26) and/or the female pulls her cloaca away (27).

In some lacertids (here in Hermon) neither sex pulls the cloaca away, though the male's tail usually does relax after the last tail-base movement. This makes the end of the copulation phase, and thus the beginning of the post-copulatory bite, an apparently indistinctly demarcated event. We then opt for the full relaxation of the male's tail, which occurs immediately after the end of the tail-base motion series, as terminating

the copulation. This seems justified, as in all other *L. cf. kulzeri* forms the male next clearly pulls his cloaca away, effectively ending intromission.

Post-copulatory bite

During the post-copulatory bite the pair may remain stationary (29) and chewing of the male while holding the female in his jaws may occur (30). The post-copulatory bite phase can be ended by the male (31), and/or the female (32).

Afterward

The male walks away over the female or not (33). The female can remain stationary, walk away or run away (34).

The male may remain in curved position (35) for a certain period (1=slightly: a few seconds; 2=clearly: >15", on average 2-3 minutes). He can chase the female away (36), and/or follow her (37). The partners may bask together (38).

Behavioural characters

Courtship observations are summarised in 38 behavioural traits (appendix I).

Twenty-nine of the traits show variation among the putative species but only 21 are potentially phylogenetically informative. All traits are included in a data matrix and used as characters in the phylogenetic analysis. Twenty-three of the characters are binary, the other fifteen are multi-state characters. Some traits enumerated in appendix I are not informative for the *kulzeri* group, but are listed because they do vary among the larger group of lacertids, which will be treated in later papers.

The courtship characteristics of the specimens from Dana and Petra appeared to be identical. Consequently, they are treated as a single unit in the phylogenetic analysis.

METHODS

The data matrix is analysed by means of a maximum parsimony approach as implemented in PAUP (version 4.0b4a; SWOFFORD, 2000). PAUP is run with the option Exhaustive Search (unrooted trees, no topological constraints). The evolution of the separate behavioural characters is traced by using MacClade (version 3.0.8, MADDISON & MADDISON, 1992). A permutation tail probability test (PTP; FAITH & CRANSTON, 1991) as implemented in PAUP is performed to check for cladistic structure in the data matrix. The effect of random errors on cladistic structure in the data matrix (Hovenkamp, 1999) is investigated by means of the program WinCarp (Hovenkamp, 2001) in combination with NONA (Goloboff, 1998). WinCarp is run with the characters unordered and with a single permutation for all entries in the data matrix. The outgroups are excluded. When more than one most parsimonious cladogram results from one permutation every cladogram is used in the evaluation instead of the strict consensus.

RESULTS

The maximum parsimony analysis (PAUP) of the data matrix results in one most parsimonious cladogram with a length of 61 steps (fig. 1), and a consistency index (CI) of 69% (62% when excluding constant and uninformative characters). The average length of the 135135 examined cladograms is 74 steps (sd = 2.88, $g1 = -0.4983$, $g2 = 0.05554$).

The observed degree of cladistic structure as indicated by cladogram length cannot be regarded as the product of random data, as shown by a PTP test (10.000 permutations, $p = 0.0138$).

HIER FIG. 1.

The cladogram is rooted, using the two *L. laevis* forms as an outgroup. The main aspect of the resulting tree (fig. 1), is that at each bifurcation only a single form branches off. Northern Lebanon is the first taxon to split off, followed by Ma'alula, Sannin, DanaPetra, Hermon, and finally the sistergroup pair Druze and Barouk. A WinCarp analysis resulted in a total of 494 most parsimonious cladograms over 266 (7 taxa x 38 characters) single permutations. The Carp-support indices associated with each group in the cladogram of figure 1 are presented in table II.

TABLE II. Carp-support indices for each group in the cladogram from figure 1.

| Group | Carp-support index |
|---------------------------------------------------------------------|---------------------------|
| Barouk + Druze | 89 |
| Barouk + Druze + Hermon | 68 |
| Barouk + Druze + Hermon + DanaPetra | 76 |
| Barouk + Druze + Hermon + DanaPetra + Sannin | 71 |
| Barouk + Druze + Hermon + DanaPetra + Sannin + Ma'alula | 81 |
| Barouk + Druze + Hermon + DanaPetra + Sannin + Ma'alula + N.Lebanon | 100 |

DISCUSSION

By means of a maximum parsimony method, employing behavioural characteristics, we arrived at a single most parsimonious cladogram with a length of 61 steps. An objective criterion to indicate the quality of phylogenetic trees is the Consistency Index. The value found here (CI=0.69) falls well within the expected range, given the number of taxa (SANDERSON & DONAGHUE, 1989).

As noted by KITCHING et al. (1998) the results of a PTP test might be viewed as a relative measure of the overall confidence in the data matrix. Since the PTP test shows a significant result, we have confidence in the cladogram in figure 1, being

our best estimate of the phylogenetic relationships between the lizards of the *L. kulzeri* complex.

The Carp-support indices (table II) for groups in a cladogram do not represent the result of a statistical test. That means that they have no benchmark against which they can be judged for their significance. As this analysis is fairly new there are as yet no examples from the literature to compare our results. Also these indices are not comparable to bootstrap values acquired by analogous procedures for sequence data. Those are generated by repeatedly analysing new data matrices based on resampling otherwise unmanipulated characters from the original data matrix. Carp-support indices simply indicate how often each group is replicated when we do a parsimony analysis on a data matrix in which only one entry is changed, and we repeat this process for all entries in this matrix. When the cladistic structure of the data is very strong these small permutations will have only a minor effect and we expect to find the same groups repeatedly. When the level of noise in the data matrix becomes larger, these small random permutations weaken the phylogenetic signal even further and groups in the most parsimonious cladogram may appear to have a weak basis in the sense that their presence is susceptible to small random fluctuations in the data matrix. From this perspective the weakest group in our cladogram is Barouk + Druze + Hermon (68 %), followed by Barouk+Druze+Hermon+DanaPetra (71 %). We consider the Carp-support indices (table II) sufficiently high to regard the groups in the cladogram (fig. 1) as being well supported.

Evolution of courtship behaviour in the *Lacerta kulzeri* complex

In agreement with BISCHOFF & SCHMIDTLER (1999) we have chosen the *Lacerta laevis* group as outgroup for the *L. kulzeri* complex. Establishing an outgroup enables us to ascertain the synapomorphies for the *L. cf. kulzeri* (see fig 1). The *L. cf. kulzeri* thus share a long introduction duration (1: 2 see appendix 1: courtship character 1, state 2) with only in DanaPetra a reversal to the ancestral state, a remnant of the mating march remains (3: 1) (*vs.* a complete march in *L. laevis*), front-legs motions female appear in the introduction (5: 1), the male does not open his jaws near copulation end (17: 0) (secondarily present in DanaPetra and Hermon), and the male does not remain put as in *L. laevis* but walks away afterward (33: 2).

One form of *L. cf. kulzeri* branches off at each bifurcation, beginning with Northern Lebanon in which the copulation duration increases (8: 2); the angle head male - axis female decreases (15: 1); amplitude of the male tail-base motions increases (19: 2); the highest number of male tail-base motions (20: 3) is recorded (an autapomorphy); the male's tail relaxes only slightly near the end (25: 1); and the male follows the female afterward (37: 1), a character state shared only with DanaPetra.

For the remaining six forms three apomorphies are found: the male shifts sides female (6: 1); the cloacae are clearly raised at the onset of copulation (9: 2); and the male positions his free front leg on the female's dorsum (10: 1). The latter two character states remain constant in the younger forms, which means that only the first *L. cf. kulzeri* branch (Northern Lebanon) retains the ancestral states.

Ma'alula splits off with as autapomorphies a high nodding female in the introduction (4: 2) and the male chasing the female away afterward (36: 1). Additionally a further increase of copulation duration (8: 3) is found.

Synapomorphies for the next five forms (Sannin-Barouk) are: the absence of female introductory front-leg motions (5: 0), only present in the oldest forms (Northern Lebanon, Ma'alula); the frequency change tail-base motions male increases (21: 1) (as this character goes through four transformations, it appears of little phylogenetic value); and there is an indication that the female ends the post-copulatory phase (31: 1).

Sannin is characterised by the occurrence of a male threat display in the introduction (2: 1) (also present in Druze); a low nodding female (4: 1); and a male that only slightly pulls his cloaca away (26: 1).

The subsequent four forms (DanaPetra-Barouk) are grouped on the male who opens jaws near end (17: 1) (secondarily present in DanaPetra and Hermon); an amplitude increase tail-base motions (19: 2); and a substantial change in its frequency (21: 2); the female no longer runs but walks away afterward (34: 2); and the male does not remain in a curved position (35: 0). This branch also marks the north-south partition in the cladogram.

DanaPetra shares with Northern Lebanon a small head angle (15: 1), and the male following the female afterward (37: 1); obviously independent developments.

DanaPetra further shows four autapomorphies: a short pleisiomorph introduction (1: 1), (rapid) cloacal end thrusts male (22:1, 23: 1), and an absence of male tail relaxation (25: 0). A diminishing relaxation of the male's tail (25: 0/1) apparently evolved independently in both Northern Lebanon and DanaPetra.

In the next clade (Hermon, Druze, Barouk) a full mating march returns (3: 2) but will disappear completely in Barouk. All three forms have a medium number of tail-base motions (20: 2) (the observed high number (20: 3) in NL is an independent

acquisition). The longest post-copulatory bite duration (28: 2) is recorded as a synapomorphy for this clade. Beginning with Hermon, a longer copulation duration (8: 4) arises, with a shorter pleisiomorph interlude in Sannin and DanaPetra (8: 1). Hermon is characterised by three autapomorphies: very pronounced female front-leg motions during copulation (12: 2), the male does not pull his cloaca away at copulation end (26: 0) and, almost certainly linked to that, the male remains in a clearly curved position afterward (35: 2). This character state also occurs in the Levant *laevis*. However, as in the latter the male remains motionless, the Hermon male initially walking a very short distance, these behaviours appear not to be homologous. Hermon is additionally typified by a male tail-base amplitude which reverses to minimal (19: 1); and also a reversed state in male not shifting sides (6: 0), a reversion as the character state is also found in Northern Lebanon.

In the sisterspecies Barouk and Druze the male opening jaws near copulation end is secondarily lost (17: 0); the tail-base frequency change is slight (21: 1); the post-copulatory phase is not ended by the female (32: 0) (as in Northern Lebanon and Ma'alula); the male tends to walk away over the female (33: 1); and synapomorphically the female remains stationary afterward (34: 1). The evolutionary tendency for a female *L. cf. kulzeri* leads from running to walking away, and finally to staying put.

In Druze the threat display changes from absent to present (2: 1), thus occurs independently from Sannin where the same state is found; there is low nodding of the female (4: 1); the copulation duration shortens to some extent (8: 3); and the front-leg motions of the female are no longer markedly present (12: 1).

In Barouk we find four autapomorphies: an absent mating march (3: 0); initial tail-lashes male present at copulation start and end (11: 1, 24: 1); and the male always

walks away over the female (33: 1). Lastly, Barouk has a short post-copulatory bite, a return to the plesiomorph state (28: 1).

Several characters seem related to habitat variables, or may form behavioural syndromes (see below). The value of some characters is hard to assess in the present group, e.g. amplitude tail-base motions male (19). These motions are hardly visible in some forms, quite clearly present in others, and it may well be that the distinction in two categories does not offer enough differentiating information. Characters such as 21 (frequency change tail-base motions) show frequent state changes and seem of low phylogenetic value.

Summarising, in all forms younger than Northern Lebanon the male shifts his introductory grasp of the female from one side to another (except in Hermon), the cloacae are raised and the male's free front leg rests on the female's back. After Ma'alula branches off, the remaining five (Sannin-Barouk) share the absence of female front-leg motions in the introduction, and have in common an increase in frequency change of male tail-base motions. Next, Sannin splits off and in the four forms left (DanaPetra-Barouk) the male opens his jaws near the end, and the female no longer runs but walks away after copulation. After DanaPetra separated, the last three forms (Hermon-Barouk) share a medium number of male tail-base motions, and at last a longer copulation is favoured. With Hermon branched off, Druze and Barouk share the tendency of the male to walk away over the female, and a female that remains stationary afterward. These five stages of evolutionary development do not appear to represent a coherent evolutionary pathway. The stages as such seem interchangeable.

Behavioural syndromes

Though all courtship characters are considered as being independent – a basic assumption in a phylogenetic analysis – this may not actually be the case. Particular groups of characters may form (functionally) related units, *i.e.* are behavioural syndromes. In that case, clades may be typified by character state complexes or syndromes, instead of one or more separate independent characters. Co-occurrences of autapomorphies are not considered to represent a behavioural syndrome, as we look for characters that support internal nodes. Visual inspection of fig. 1 may reveal such incidence of clustering of characters.

It seems clear that some characters indeed may form syndromes. In a social context, aspects of male lacertid threat behaviour, as shown here in the introductory threat display (2) and mating march (3), are frequently responded to by female head nodding and/or front-leg motions (coined Treteln: KRAMER, 1937), and tail movements (4, 5, 7, 12, 13). Treteln is commonly interpreted as an indication of submissiveness (KITZLER, 1941). However, in *L. cf. kulzeri* courtship a similar association between aggressive and submissive gestures is only indicated in Druze. The very pronounced front-leg motions of the female during copulation (12: 2), an autapomorphic trait in Hermon, are apparently unrelated to any male aggressive elements because these are conspicuously absent. Remarkably though, as just mentioned, these motions are still indicated in Druze (12: 1) in which – at least in the introduction – a male threat display is present (2: 1).

Only in Hermon the male does not pull his cloaca away (26: 0), which could be linked to the presence of the longest post-copulatory bite in this form (28: 2; table III). However, in Druze, with a just minimally shorter post-copulatory bite (table III)

the male pulls his cloaca away substantially (26: 2), as do forms in which the post-copulatory bite is shortest.

TABLE III. Durations (seconds), mean \pm sd, of courship elements in the *Lacerta kulzeri* complex.

| Form | Copulation | post-copulatory bite | Copulation+post-copulatory bite | Introduction +copulation +post-copulatory bite |
|-----------------------------------|-----------------|----------------------|---------------------------------|------------------------------------------------|
| <i>Lacerta laevis</i> | | | | |
| <i>L. l. laevis</i> Levant (n=15) | 18.1 \pm 4.0 | 4.6 \pm 3.2 | 22.1 \pm 4.2 | 47.4 \pm 12.1 |
| <i>L. l. troodica</i> (n=15) | 16.4 \pm 1.1 | 2.0 \pm 1.5 | 18.4 \pm 1.4 | 29.0 \pm 6.0 |
| <i>L. cf. kulzeri</i> | | | | |
| Northern Lebanon (n=7) | 29.5 \pm 3.1 | 2.2 \pm 0.9 | 31.2–2.9 | 61.2–7.5 |
| Ma'alula (n=8) | 39.6 \pm 9.3 | 5.1 \pm 3.5 | 44.5–10.3 | 111.0–32.0 |
| Sannin (n=11) | 23.8 \pm 3.2 | 4.7 \pm 3.2 | 28.6–4.1 | 89.3–20.2 |
| Dana+Petra (n=13) | 19.6 \pm 4.4 | 5.7 \pm 3.4 | 29.0–4.3 | 55.5–8.2 |
| Hermon (n=10) | 57.4 \pm 16.1 | 21.1 \pm 13.5 | 86.5–25.4 | 160.1 \pm 40.3 |
| Druze (n=10) | 38.9 \pm 7.7 | 18.8 \pm 15.8 | 57.7–18.2 | 107.0–37.5 |
| Barouk (n=6) | 56.2 \pm 10.2 | 9.3 \pm 7.5 | 65.0–8.5 | 123.0–17.9 |

The tail-base motions of the male (19-25) may appear to be related. Rapid cloacal end thrusts (22) and duration of end thrusts (23) are obviously aspects of the same phenomenon, but here autapomorphies of DanaPetra which – as explained above – do not form behavioural syndromes. The presence of rapid cloacal end thrusts (22) will influence the state of character 21, frequency change tail-base motions male.

The degree of stiffness needed to perform tail movements, could affect the extent of male tail relaxation near the end (25). Curiously enough, other aspects of the male's tail (amplitude and number of tail-base motions: 19, 20) are independent, and the lashes (11, 24) also do not belong to the syndrome.

Copulation ended by the male (31) or the female (32) seems mutually exclusive, though separation might occur by common consent. If afterward the male remains in a curved position (35), he cannot walk away over the female (33), nor – at least immediately – follow (37) or chase her (36). (Though a correlation between 35 and 36 is suggested by appendix I, these behaviours are temporally separated.) A female that walks away (34: 2, 3), can preclude a male walking over her (33). In conclusion, in the *L. kulzeri* group behavioural syndromes can hardly be recognised in the phylogenetic context.

Correlations with habitat variables

As mentioned earlier, the two *L. laevis* forms occupy relatively level, vegetated areas, while the *L. kulzeri* generally favour rocky outcrops in higher altitude areas with sparser vegetation. With codes for these habitat preferences added to the cladogram in figure 1, the following picture emerges.

After Northern Lebanon there is a clear shift to a more vertical, rocky habitat with sparse vegetation. The behavioural modifications that accompany this change are 6, 9 and 10 (fig 1). The latter two, cloacae stance and position front legs male, could be correlated with habitat (see: Comparison with morphology).

Hermon and Druze already prefer a more level microhabitat, and Barouk is mainly ground-dwelling. And while Hermon is still found under relatively sparsely vegetated conditions, Druze and especially Barouk live in increasingly greener regions. This habitat shift is associated with a change in 3, 8, 20 and 28, *i.e.* a full mating march in Hermon and Druze (next lost in Barouk) and a longer copulation and post-copulatory bite. The plesiomorph presence of the mating march thus

changes to indicated in the northern forms and DanaPetra (3: 1), returns to present in Druze and Hermon (3: 2), and is lost in Barouk (3: 0). As a full mating march is facilitated by a level substrate, it is not surprising to find it present in the *L. laevis* complex, but only indicated in the saxicolous *L. kulzeri* forms. Hermon and Druze tend to spend considerable time on a more horizontal plane (HidB, pers. obs.). Barouk has a comparable level habitat, but additionally lives in much more vegetated areas, which may hinder expression.

Any habitat will impose certain restrictions. It seems obvious that because of (*e.g.* predatory) risks, a very exposed environment will not favour long courtship durations. Even though the three youngest *L. cf. kulzeri* in relatively vegetated habitats show longer copulations, Northern Lebanon under similar circumstances copulates slightly shorter, the exposed Ma'alula as long as Druze. The length of the post-copulatory bite increases in Hermon and Druze (28: 2), but returns to the pleisiomorph state (28: 1) of just a few seconds in Barouk. Conceivably, on this time scale averaging between 29-160 seconds, no obvious relation between duration of separate courtship components and habitat parameters can be expected.

Comparison with morphology

Little variation is encountered in cloacae raised (9) and position front legs male (10). The first branch, Northern Lebanon, retains the ancestral state for both characters. Thus, in the *L. laevis* and the youngest *L. kulzeri* raised cloacae are indicated, and the male places his front legs on the substrate. Later the cloacae are clearly raised and the male's free front leg rests on the dorsum of the female.

Limb proportions correlate clearly with the structural habitats occupied by lacertid species, ground-dwelling forms have relatively short limbs while climbers usually have rather longer legs (ARNOLD, 1998). *L. laevis* are mainly ground dwelling and certainly have shorter limbs (ARNOLD, 1998), than the saxicolous *L. kulzeri* as exemplified by Petra (BISCHOFF & MÜLLER, 1999). However, not all *L. kulzeri* forms have equally long legs, the ratio hind-leg length : head-body length varies from 49% in Northern Lebanon to 58% in Petra (pers. obs., BISCHOFF & MÜLLER, 1999), while in *L. laevis* an average of 43% is found (pers. obs.). In fact, all *L. kulzeri* forms evolutionary younger than Northern Lebanon have comparatively longer legs, which could well explain the positioning of the male's fore legs on the female's dorsum (10: 1) in all *L. kulzeri* except Northern Lebanon, as well as the raised cloacae (9: 2) that are the result of the male stretching his hind legs, with longer legs obviously giving a higher rise.

HIER FIG. 2.

From a gross morphological point of view Ma'alula and Northern Lebanon seem moderately similar. Ethologically, however, they differ in 11 character states. The forms are considered sister species (or even identical) by BISCHOFF & SCHMIDTLER (1999) due to morphological similarities and their geographical distribution. We disagree, as they only share two synapomorphies (introductory female front-leg motions, 5: 1) and absence of a frequency change in tale-base motions (21: 0), of which the latter represents a plesiomorphic condition.

Similarly, Hermon and Barouk are judged sister species by BISCHOFF & SCHMIDTLER (1999). Though we consider these forms closely related, they are not sister species. Synapomorphically they share the longest copulation (8: 4).

As part of a larger morphometric study including seven *Lacerta laevis* forms as well as seven *L. cf. kulzeri* populations, BISCHOFF & SCHMIDTLER (1999) presented a dendrogram based on Manhattan distances and UPMG clustering. In this dendrogram, the first dichotomy is between the *L. laevis* group and the *L. kulzeri* complex. The part of the dendrogram with the relevant species from the *L. kulzeri* complex is depicted in figure 2, including a parsimony mapping of all courtship characters from appendix I. Comparison of the two diagrams (fig. 1 vs. fig. 2) is hampered because they are based on different methods as well as different data and it is difficult to tell apart the effect of each factor. However, it is clear that the result of the morphological study is based on overall similarity, and is therefore inherently non-phylogenetic. The method applied by BISCHOFF & SCHMIDTLER (1999) does not distinguish similarity based on recent ancestry (apomorphies), from similarity based on plesiomorphies and homoplasy (parallelism and convergence) and mixes both freely. Our result (fig. 1) is strictly based on apomorphic similarities and all relationships among taxa depicted are based on recency of common ancestry. The BISCHOFF & SCHMIDTLER (1999) dendrogram for the *L. kulzeri* complex (fig. 2) is not most parsimonious; it is eight steps longer (69 vs. 61) than our cladogram (fig. 1). We reject the diagram in fig. 2 as a likely hypothesis of the evolutionary relationships within the *L. kulzeri* complex in favour of the cladogram depicted in fig. 1 based on behavioural characters.

Comparison with molecular data

Parsimony analysis of the 12S gene sequence from mitochondrial rDNA (IN DEN BOSCH et al., MS) renders a preliminary cladogram (fig. 3) onto which the behavioural characters from appendix I are mapped by using MacClade. This cladogram is 65 steps long (under the option of hard polytomies), and thus four steps longer than the cladogram based on behavioural characters only (fig. 1). This again would lead us to prefer the behavioural cladogram. However, since the molecular data as well as the karyological results are still being evaluated this may lead to a slightly different molecular cladogram (in particular the position of DanaPetra may change). Presently it suffices to point out a general similarity between the molecular and behavioural cladograms, and a disparity with the morphological dendrogram.

HIER FIG. 3.

Conclusions

This study leads to a clear hypothesis about the phylogenetic relationships of the forms within this assemblage. It demonstrates that at this taxonomic level, a behavioural analysis may provide useful phylogenetic information, and from which an understanding of the evolutionary development of courtship behaviour may result. The internal nodes of the cladogram (fig. 1) can be seen as representing stages in the evolutionary development of courtship behaviour in the *L. cf. kulzeri* group. As such, these stages do not appear to epitomise a coherent evolutionary pathway, with the possible exception of increasing courtship duration. This latter trend is possibly correlated with an increased preference for a more vegetated, horizontal

microhabitat. As regards behavioural syndromes, there are hardly any indications for their existence that may have relevance for the present phylogenetic analyses. The behavioural cladogram (fig. 1) of the *L. cf. kulzeri* complex is preferred over two alternatives based on morphological and molecular data. Parsimony mapping of the behavioural characters on the alternative trees clearly shows these to be longer.

ACKNOWLEDGEMENTS

W. Bischoff and J.F. Schmidtler provided animals and were pleasant companions on two of HidB's field trips. They also kindly provided a pre-press version of their morphological analysis, for which we are grateful. We thankfully used preliminary results of molecular analyses by G. Odierna and E. Olmo. J. Müller and D. Modrý donated material. P.Hovenkamp kindly made available a beta version of his program WinCarp, for which we are very grateful. Discussions with C. ten Cate are much appreciated.

REFERENCES

- ANDERSON, L.R., 1981. Evolution of the telencephalic function in lower vertebrates. In: P.R. Laming (Ed.): *Brain mechanisms of behaviour in lower vertebrates*: 33-58. Cambridge University Press, Cambridge.
- ARNOLD, E.N., 1998. Structural niche, limb morphology and locomotion in lacertid lizards (Squamata, Lacertidae); a preliminary survey. *Bull. nat. Hist. Mus. Lond. (Zool.)* **64**(1): 63-89.
- ATZ, J.W., 1970. The application of the idea of homology to behavior. In: L.R. Aronson, E. Tobach, D.S. Lehrman & J.S. Rosenblatt (Eds.): *Development and*

Evolution of behavior: essays in honor of T.C. Schneirla: 53-74. Freeman, San Francisco.

BISCHOFF, W. & J. MÜLLER, 1999. Revision des levantinischen *Lacerta laevis/kulzeri*-Komplexes: 2. Die Petra-Eidechse *Lacerta kulzeri petraea* ssp.n. Salamandra **35**: 243-254.

BISCHOFF, W. & J.F. SCHMIDTLER, 1994. Ergebnisse zweier Lacertiden-Exkursionen nach Syrien. Die Eidechse **5**(12): 4-22.

BISCHOFF, W. & J.F. SCHMIDTLER, 1999. New data on the distribution, morphology and habitat choice of the *Lacerta laevis-kulzeri* complex. Natura Croatica **8**(3): 211-222.

BISCHOFF, W. & J.F. SCHMIDTLER (in ms.). Das *Lacerta kulzeri*-Komplex.

BOSCH, H.A.J. IN DEN, 1998. Prodromus Amphibiorum et Reptiliorum Phoeniciae. Faun. Abh. staatl. Mus. Tierk. Dresden **21**/Suppl.(2): 9-17.

BOSCH, H.A.J. IN DEN, 1999. Die Eidechsen des Mount Hermon im Biotop, mit ersten Daten zur Fortpflanzung. Elaphe **7**(4): 68-75.

BOSCH, H.A.J. IN DEN (in ms.). Amphibia & Reptilia of Lebanon, an annotated checklist and fieldguide.

BOSCH, H.A.J. IN DEN, W. BISCHOFF & J.F. SCHMIDTLER, 1998. Mit dem Finger auf der Landkarte entdeckt: Eidechsen auf dem Djebel Druz. Die Eidechse **9**(1): 1-9.

BOSCH, H.A.J. IN DEN & R.G. BOUT., 1998. Relationships between maternal size, egg size, clutch size, and hatchling size in European lacertid lizards. J. Herpetol. **32**: 410-417.

BOSCH, H.A.J. IN DEN, G. ODIERNA, G. APREA, T. CAPRIGLIONE, E. OLMO & A. CANAPA (in ms.). Karyological and 12S rDNA analyses of the Middle Eastern *Lacerta kulzeri* complex.

- FAITH, D.P. & P.S. CRANSTON, 1991. Could a cladogram this short have arisen by chance alone?: On permutation tests for cladistic structure. *Cladistics* **7**: 1-28.
- GOLOBOFF, P.A. 1998. NONA. Program and documentation. Published by the author. Tucuman, Argentina.
- HEINROTH, O., 1911. Beiträge zur Biologie, namentlich Ethologie und Psychologie der Anatiden. Verhand. Ver. int. Ornithol. Kongr., Berlin (1910): 589-702.
- HOVENKAMP, P. 1999. Unambiguous data or unambiguous results? *Cladistics* **15**: 99-102.
- HOVENKAMP, P. 2001. WinCarp; program and documentation.
- KITCHING, I.J., P.L. FOREY, C.J. HUMPHRIES & D.M. WILLIAMS, 1998. *Cladistics. The theory and practice of parsimony analysis*. Oxford University Press, Oxford.
- KITZLER, G., 1941. Die Paarungsbiologie einiger Eidechsen. *Z. f. Tierpsych.* **4**: 353-402.
- KRAMER, G., 1937. Beobachtungen über Paarungsbiologie und soziales Verhalten von Mauereidechsen. *Z. Morph. Ökol. Tiere* **32**: 752-783.
- LORENZ, K., 1941. Vergleichende Bewegungsstudien an Anatiden. *J. Ornithol.* **89**: 194-294.
- MADDISON, W.P. & D.R. MADDISON, 1992. *MacClade. Analysis of phylogeny and character evolution*. Sinauer Ass. Inc., Sunderland, Massachusetts.
- MÜLLER, J., 1994. Eidechsenbeobachtungen in Jordanien. *Die Eidechse* **6**(14): 17-19.
- ODIERNA, G., G. APREA, H. IN DEN BOSCH, T. CAPRIGLIONE & E. OLMO, 1998. *Lacerta kulzeri* complex, un caso di speciazione cromosomica allopatrica. Abstr. Congr. Soc. herpetol. Ital. 1998: 61-62.

- QUEIROZ, A., DE & P.H. WIMBERGER, 1993. The usefulness of behaviour for phylogeny estimation: levels of homoplasy in behavioural and morphological characters. *Evolution* **47**: 46-60.
- RYAN, M.J., 1997. Phylogenetics in behavior: some cautions and expectations. In: E.P. Martins (Ed.): *Phylogenies and the comparative method in animal behaviour*: 1-21. Oxford University Press, Oxford.
- SANDERSON, M.J. & H.J. DONAGHUE, 1989. Patterns of variation in levels of homoplasy. *Evolution* **43**: 1781-1795.
- SCHMIDTLER, J.F. & W. BISCHOFF, 1999. Revision des levantischen *Lacerta laevis/kulzeri*-Komplexes: 1. Die Felseneidechse *Lacerta cyanisparsa* sp.n. *Salamandra* **35**: 129-146.
- SWOFFORD, D.L., 2000. PAUP*: *Phylogenetic analysis using parsimony (* and other methods)*. Version 4. Sinauer Ass., Sunderland, Massachusetts.
- TINBERGEN, N., 1959. Comparative studies of the behaviour of gulls (Laridae): a progress report. *Behaviour* **15**: 1-70.

Fig. 1. Cladogram of the *Lacerta kulzeri* complex. All character states indicated. B=Barouk, D=Druze, DP=Dana and Petra, H=Hermon, M=Ma'alula, NL=Northern Lebanon, S=Sannin. L=Levant *Lacerta laevis laevis*, C=Cypriot *Lacerta laevis troodica*. Habitat characters are indicated on top of the terminal taxa: r=rocky, l=level, o=open, d=denser bush.

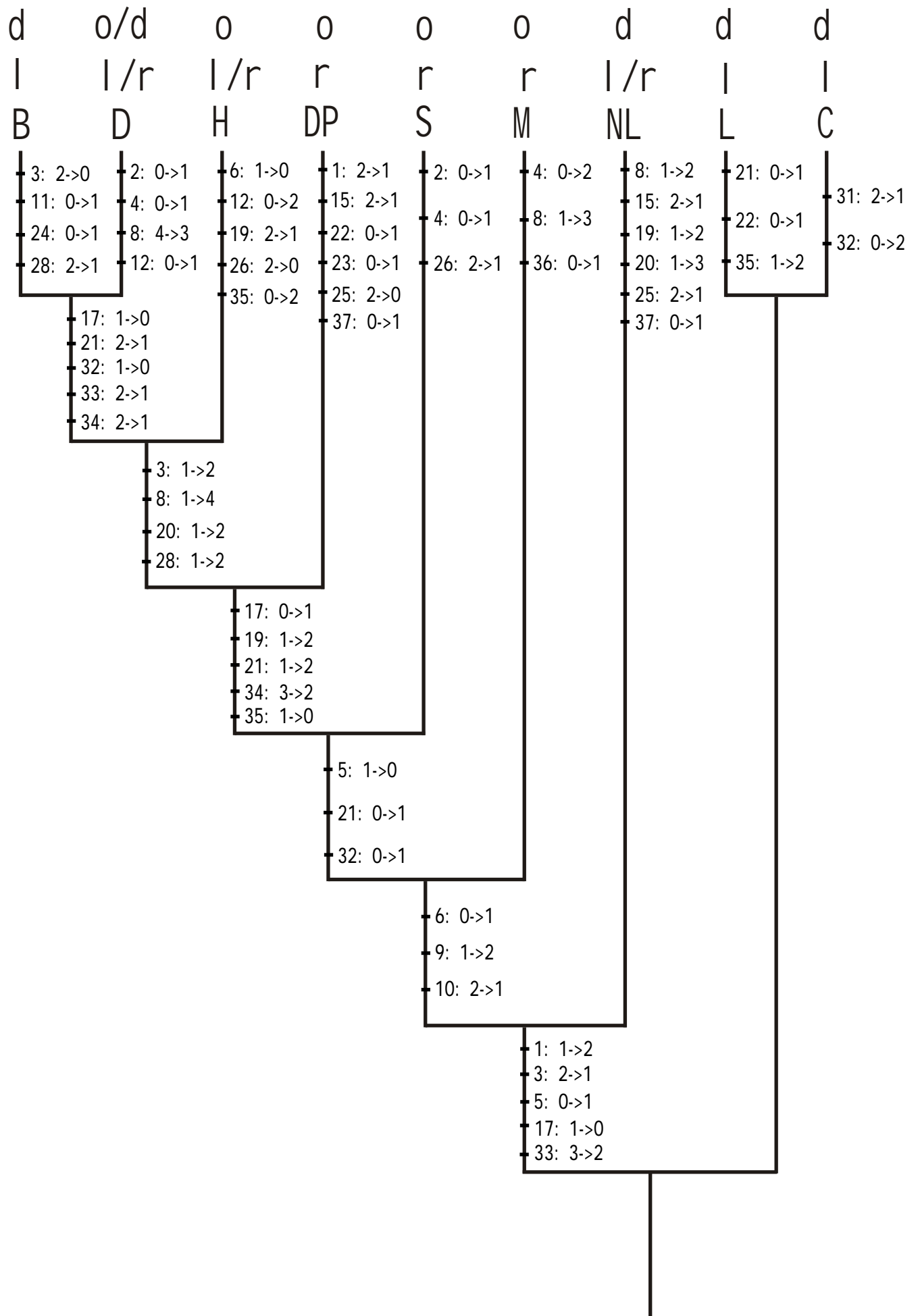

Fig. 2. Cladogram of the *Lacerta kulzeri* complex based on morphological characters (Bischoff & Schmidtler, 1999) with all behavioural character states indicated. B=Barouk, D=Druze, DP=Dana and Petra, H=Hermon, M=Ma'alula, NL=Northern Lebanon, S=Sannin. L=Levant *Lacerta laevis laevis*, C=Cypriot *Lacerta laevis troodica*.

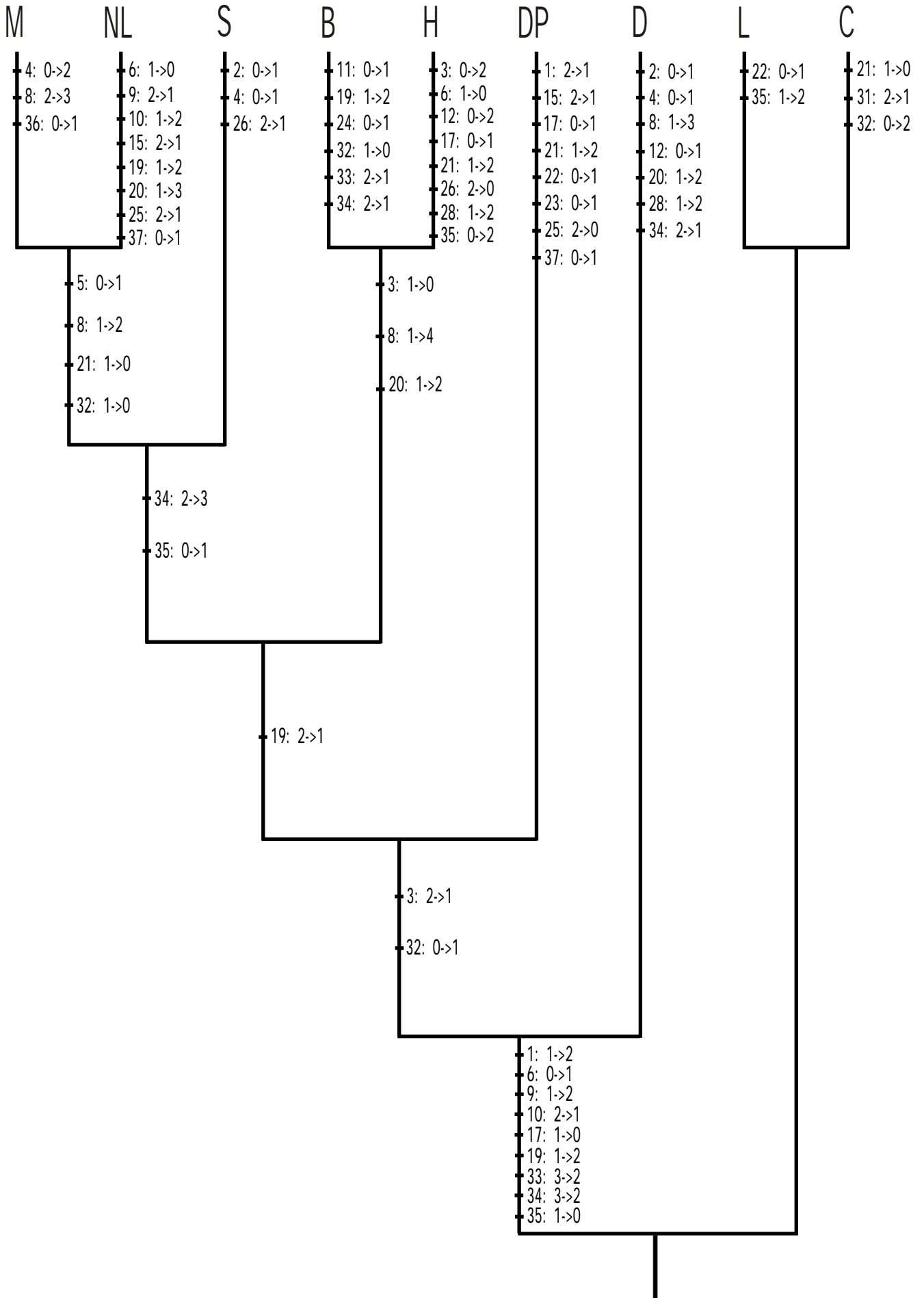

Fig. 3. Cladogram of the *Lacerta kulzeri* complex based on 12S mtRNA sequence data (in den Bosch et al, MS) with all behavioural character states indicated. B=Barouk, D=Druze, DP=Petra, H=Hermon, M=Ma'alula, NL=Northern Lebanon, S=Sannin. L=Levant *Lacerta laevis laevis*, C=Cypriot *Lacerta laevis troodica*.

